



**OPERATOR'S MANUAL  
FOR**

**EXPS2™**

HWS® (HOLOGRAPHIC WEAPON SIGHT)

See inside cover for distribution statement.

EOTech Technical Manual ver. F

JUNE 2015



An L-3 Company

DISTRIBUTION STATEMENT: Distribution is authorized to U.S. Government agencies and their contractors. This publication is required for administration and operational purposes. Additional copies of this document can be found on the manufacturer's website. Written requests must be referred to:

L-3® EOTech® Service Dept.  
Attn: TM Request  
1201 E. Ellsworth Rd.  
Ann Arbor, MI 48108  
(734)741-8868 x2176  
[general.eotech@L-3com.com](mailto:general.eotech@L-3com.com)

- This commodity is controlled under the Export Administration Regulations (EAR), ECCN 0A987, and may not be exported to a Foreign Person, either U.S. or abroad, without a license or exception from the U.S. Department of Commerce.

# WARNING

**WEAPON SAFETY:** Prior to mounting the HWS® on your weapon, **be sure the weapon is cleared.** If you are not sure how to clear your weapon, please see the accompanying operator's manual for the weapon platform you are mounting the sight on.

**LASER SAFETY:** The HWS® is a Class II laser product. The Class II level illuminating beam, however, is completely blocked by the housing. The only laser light accessible to the eye is the image beam and is at a power level within the limit of a Class IIa laser product. The illuminating beam can become accessible to the eye if the housing is broken. Turn the sight off immediately and return the broken unit to the factory for repair.



**FCC COMPLIANCE:** The HWS® complies with Part 15 of the FCC Rules. Operation is subject to the following conditions: (1) this device may not cause harmful interference and (2) this device must accept any interference received, including interference that may cause undesired operation. Complies with 21 CFR Chapter 1, Subchapter J.

**This page was intentionally left blank.**

## CAUTION

- Never disassemble the sight's optical assembly. The optical cavity is purged, nitrogen filled, and sealed to achieve fog resistant performance. **Disassembly will void the warranty and render the sight inoperable.**
- When using a Night Vision compatible HWS® in tandem with an NV device, always check to make sure the sight is off before pressing the NV button to turn on the sight in the Night Vision mode. Otherwise, it will toggle to the Normal mode and saturate the image intensifier.
- When a sudden increase in resistance is felt in the elevation or windage adjustment shafts, the end of the adjustment range has been reached. **DO NOT TURN THE ADJUSTMENTS ANY FARTHER OR SERIOUS DAMAGE MAY OCCUR TO THE SIGHT.**
- Never clean the glass surface with a dry cloth or paper towel; always dampen the glass surfaces prior to cleaning.
- All moving parts of the sight are permanently lubricated with the exception of the quick release lever. If audible sounds are generated when opening/closing lever, add a drop of lubricant to lever assembly. Do not try to lubricate any other moving part.

- Do not use deteriorated or corroded batteries. Inspect batteries for rips, tears, dents, or cuts in the housing. If there is any exposed, internal content of the battery, it could affect the operation of the sight.
- The EXPS2 HWS® units are designed to mount directly to either a 1”(25.4mm) weaver or MIL-STD-1913 rail specification.

	Page
1.0 INTRODUCTION .....	1
1.1 General Information .....	1
1.2 Key Attributes.....	2
1.3 Equipment Description.....	5
1.4 Location and Description of Major Components .....	7
2.0 OPERATING INSTRUCTIONS.....	9
2.1 Description of Components, Controls, and Indicators .....	9
2.1.1 Hood.....	10
2.1.2 Batteries .....	10
2.1.3 Replacing Batteries .....	12
2.1.4 Electronic Features .....	13
2.1.5 Windage and Elevation Adjustments .....	15
2.2 Preventive Maintenance Checks and Services (PMCS) .....	17
2.3 Troubleshooting .....	18
2.4 Unit Level Maintenance and Repair .....	22
2.5 Installation of Equipment .....	24
2.6 Zeroing Procedures .....	25

3.0	APPENDIX A, COMPONENTS OF END ITEM.....	27
3.1	Replacement Items.....	27
4.0	APPENDIX B, FACTORY CONTACTS.....	28



## **1.0 INTRODUCTION**

### **1.1 General Information**

This manual is an overview of the EXPS2 HWS® (Holographic Weapon Sight), and will define the basic operation, features/benefits, and options of this proprietary optical system. The HWS® is a state of-the-art optical sighting system, employing holographic sighting technology for small to medium caliber weaponry and launching type platforms. The HWS® utilizes holographic optics fabrication technology that is used in the production of advanced heads up display in attack fighter aircraft for targeting, gauge reading, weapon system verification, etc. L-3® EOTech® has miniaturized the sophisticated sighting heads up display system into a compact and rugged package for use on small arms and other weapon platforms.

## **1.2 Key Attributes**

The EXPS2 HWS® is a lightweight, non-magnifying, optical sight designed for close to midrange engagements. It allows very fast target acquisition and engagement at short ranges while providing aiming capability out to 300 meters equal to or better than iron sights.

The major combat advantage of the HWS® is extremely rapid reticle-on-target acquisition. As quickly as a target is identified, the holographic reticle can be superimposed on the target. The sight allows operators to maintain eye contact on the target and to place the holographic reticle onto the target without shifting focus. Operators can quickly acquire the target and reticle in the same focal plane for fast and accurate shot placement.

The HWS® appears to project the holographic image of a reticle on the target plane. The sight can be used as a bright open reticle image or a fine dot which is limited only by the acuity of the shooter's eye. The heads up display window allows an undistorted and unrestricted view of the target.

The EXPS2 is offered with one of the following (2) reticle options (see fig. 1):

- 0- 68 minute ring with vertical and horizontal stadia and a 1 MOA aiming dot.
- 2- 68 minute ring with vertical and horizontal stadia and (2) 1 MOA aiming dots

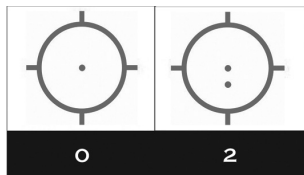

Fig. 1 EXPS2 reticle options

The HWS® offers extremely fast target acquisition in Close Quarter Battle (CQB) using the large ring, and aiming precision in longer range engagements (using the MOA Dot) without obscuring the target.

Another advantage of the HWS® is the full field of view which allows the operator better situational awareness. The HWS® employs a true heads up display (HUD) window that eliminates blind spots and constricted or tunnel vision associated with scope sights. Controls are inset into the HWS® housing with no protruding knobs, battery compartments, or rings obscuring the target. Utilizing natural binocular vision is an advantage of this sighting system, as well as additional threat identification through increased operator situational awareness and peripheral vision.

The primary use of the HWS® is for the M4A1 carbine and CQBR in Close Quarters Battle. The HWS® is not however, limited to carbines. The HWS® can also be used on medium caliber machine guns, grenade launchers, bolt guns, crossbows, and less than lethal projectile launchers. The sight provides a 1X (no magnification) sight picture and is not designed as a long range sight system, however, it can be used as effectively as iron sights on targets to 300 meters.

The advantage of the HWS® is that it provides the operator superior shooting performance, rapid reticle-on-target acquisition, full field of view and accurate shot placement. The HWS® can be naturally employed by all levels of users, from novice to the most highly trained operator.

## **1.3 EXPS2 Equipment Description**

### **Operation**

- Optics: Transmission holography
- Magnification: 1x
- Eye Relief: Unlimited
- Length/Width/Height: 3.8"x2.3"x2.9" (96.5 x 58.4 x 73.7mm)
- Weight: 11.2 oz (317.5g)
- Water resistant: Submersible to 33 ft (10m) depth
- Sealing: Fog resistant internal optics
- Color/Finish: Non-reflective black
- Adjustment (per click): Approx. 0.5 MOA (1/2" (12.7mm) at 100 yds (91m)) when zeroing
- Adjustment Range: +/- 40 MOA travel
- Mount: 1" (25.4mm) weaver or MIL-STD 1913 rail

## Display Window

- Optical Surfaces: Anti-reflection coating on external surfaces
- Window Dimensions: 1.20" x 0.85" (30 x 23mm)
- Front Window Material: Glass 1/8" (3.17mm) thick
- Rear Window Material: Laminate 3/16" (4.76mm) thick
- Field of View 100 yds (91m): 30 yds (28m) at a 3" eye relief
  
- Reticle Options: 0- 68MOA circle with quadrant ticks with 1 MOA aiming dot  
2- 68MOA circle with quadrant ticks with (2) 1 MOA aiming dots

## Electrical

- Power Source: 1 x 123 lithium battery
- Battery Life: Approximately 600 continuous hours at nominal setting 12 at room temp.
- Brightness Settings: 20 settings with scrolling feature
- Auto Battery Check Indicator: Flashing reticle upon start-up
- Auto Shut-down: At 8 hrs- programmable to 4 hrs

## 1.4 Location and Description of Major Components

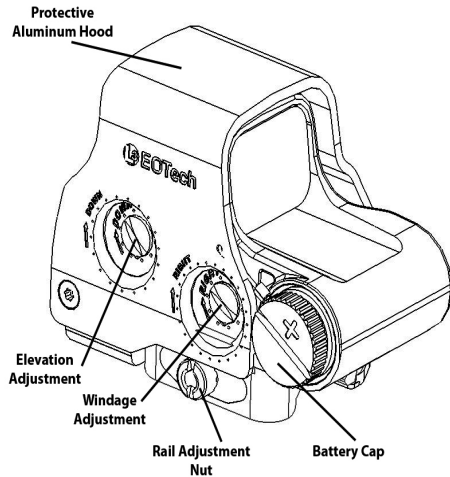

Fig 2: EXPS2 components

**Holographic Window** - Contains the embedded holographic reticle pattern that forms a virtual image of the reticle when illuminated by laser light.

**Protective Hood** - Preassembled, protective hood increases durability of sight housing and protects the sight from impact damage.

**Battery Cap**- A threaded cap that secures and seals the battery compartment to prevent water, dirt, or grime from entering the battery housing.

**Universal Mount** - Ambidextrous, quick release base mounts to either a 1" (25.4mm) Weaver or MIL-STD-1913 rail. Adjustable lever accommodates all MIL-STD 1913 rail tolerances.

**Windage Adjustment** - Adjusts the point of aim at 100 yards approx. 1/2 inch per click in a leftward and rightward direction when zeroing.

**Elevation Adjustment** - Adjusts the point of aim at 100 yards approx. 1/2 inch per click in an upward and downward direction when zeroing.

**On/Off, and Brightness Switches** - Raised button control interface allows the operator to perform and adjust user settings for appropriate and preferred conditions (see page 14).



## **2.0 OPERATING INSTRUCTIONS**

This section describes the features and operating instructions of the EXPS2. Please read the instructions carefully before mounting and using the sight, and always practice proper firearm safety.

The HWS® will include:

- Sight assembly
- 1 x Type 123 Lithium battery
- Quick Reference Card
- Product Registration/Warranty Card

### **2.1 Description of Components, Controls, and Indicators**

The HWS® uses a laser to illuminate a holographic reticle pattern embedded in the display window and forms a virtual image of a reticle pattern. The shooter looks through the display window and sees a bright red image of a reticle pattern projected onto the target plane. No light is projected onto the target plane. The HWS® has no magnification.

## 2.1.1 Hood

The HWS® is equipped with a protective hood. This hood is pre-assembled at the factory. Should your hood require repair or replacement, please contact your unit armorer for repair, replacement, or contact the manufacturer (L-3® EOTech®) for repair or replacement.

## 2.1.2 Battery

One initially supplied (1) 123 Lithium battery powers the EXPS2. The HWS® is designed to maintain constant brightness at a particular setting as the battery drains down. The reticle brightness will not fade gradually as the battery runs down, but rather, shut down abruptly. The first indication of the battery draining is the reticle blinking when the unit is turned on (see Electronic Features 2.1.4). Another indication of a low battery is the reticle pattern blinking off and on during recoil. With high recoil guns, this can occur before the battery check indicates low battery condition. *If the reticle pattern blinks off and on during recoil or turns off suddenly, replace the battery.* Please read and follow the battery replacement and battery check procedures described in this Manual. It is always good practice to replace the battery with a fresh one before a mission.

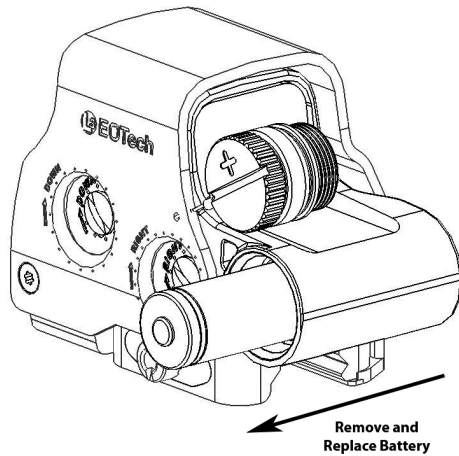

Fig 3: Proper battery Installation

### 2.1.3 Replacing the Battery

Remove the battery cap by turning the cap counterclockwise until the cap pulls away from the battery compartment (Fig. 3). After the battery cap is removed, slide the battery out and replace it with a fresh one. A “+” marking can be found on the top of the battery cap ensuring correct battery orientation. To reinstall the battery cap, align the cap with the battery compartment and carefully begin to thread the cap, turning it clockwise. ***Before you begin tightening the cap, make sure the threads are aligned correctly to avoid cross threading.*** Verify correct battery installation immediately by turning on the sight and checking if the holographic reticle appears.

**The tether can be tucked in between the battery cap and the hood to minimize the risk of snagging.**

## 2.1.4 Electronic Features

All electronic controls are via pushbutton switches located on the left side of the unit housing as shown in Fig. 4. To ensure proper operation of the pushbutton switches, press firmly on the center of the switch.

### 1. *ON/ Auto Battery Check*

Pressing the Up or Down Arrow pushbutton switches will turn the sight ON at Level 12. See item 4 under this section for a description of Auto shutdown. The sight will automatically perform a battery check every time it is turned on. The reticle will blink when the batteries have between 2.5 and 5 hours of useful life left.

### 2. *OFF*

To turn the sight off, simultaneously press both the UP and DOWN arrows. Verify that the sight is on/off by looking through the heads-up display window for the reticle.

### 3. *Brightness Adjustment*

Pushbutton switches vary the brightness intensity of the holographic reticle pattern. Pressing the UP arrow or DOWN arrow switch will change the brightness level up or down. There are twenty (20) daytime brightness settings provided to allow the user to adjust the reticle brightness to their preference.

#### 4. Auto Shutdown

The HWS® has an auto shutdown feature. If the sight is turned on by pressing the UP button, it will automatically shut itself OFF 8 hours **after the last pushbutton control is used**. The sight will automatically shut OFF after 4 hours if it is turned on by pressing the DOWN button.

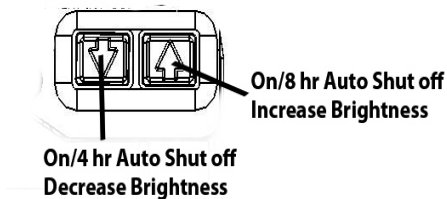

Fig 4: Pushbutton interface

## 2.1.5 Windage and Elevation Adjustments

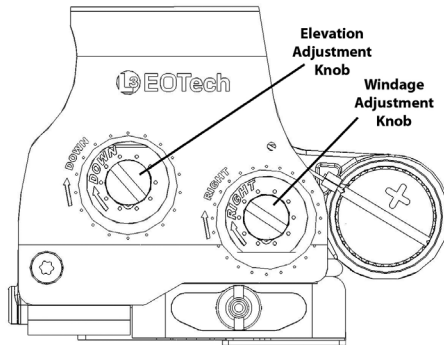

Fig 5: Adjustments

The HWS® features click mechanisms for elevation and windage adjustments. The elevation and windage adjustment are located on the right-hand side of the sight (Figure 5). The knob towards the front is the windage adjustment and the knob towards the rear is the elevation adjustment. Both of these adjustment mechanisms are grooved with a slotted screw head and

require the use of a screwdriver, coin, or spent brass to turn. The elevation and windage adjustments are shown in Fig. 5. For both elevation and windage, each click will change the sight's point of aim approximately 1/2 Minute of Angle (MOA), ¼ inch (6.35mm) at 50 yards (45.7m), or ½ inch (12.7mm) at 100 yards (91m) when zeroing. Also, one full rotation of either knob will change the point of aim approximately 10 MOA, 5 inches (127mm) at 50 yards (45.7m), or 10 inches (254mm) at 100 yards (91m) when zeroing. To move the point of impact UP, turn the elevation adjustment LEFT. To move the point of impact RIGHT, turn the windage adjustment RIGHT.

The HWS® elevation and windage adjustments are factory collimated with the bore of the rifle parallel to the mounting rail. The sight should be close to mechanical zero when mounted on a properly installed rail. **Do not** turn the adjustments before mounting the sight on the firearm. Be sure to check that the mount and sight are securely mounted after initial firing.

**CAUTION – When encountering an increase in resistance in adjustments, the end of the adjustment range has been reached. DO NOT turn the adjustments any farther, serious damage may occur to the sight.**



## **2.2 Preventive Maintenance Checks and Services (PMCS)**

### OPERATOR LEVEL MAINTENANCE

The operator is limited to replacing batteries and cleaning the battery compartment and outer housing surfaces of the sight.

### REPLACING BATTERY

See the heading 'Replacing Battery' (2.1.3) under section Description of Components, Controls, and Indicators. Do not use deteriorated or corroded batteries. Inspect battery for rips, tears, or cuts in the housing. If there is any exposed, internal content of the battery, it could potentially effect the operation of the sight.

### OPERATOR CLEANING INSTRUCTIONS

1. The optical system and the window are coated with anti-reflection material. When cleaning the glass surfaces, first blow away any dirt and dust. Fingerprints and lubricants can be wiped off with lens tissue or a soft cotton cloth, moistened with lens cleaning fluid or glass cleaner sold in any camera store. Never clean the glass surface with a dry cloth or paper towel; always dampen the glass surfaces prior to cleaning.

2. No maintenance is needed on the sight's surface, except to occasionally wipe off with a soft cloth. Use only a water-based cleaner such as glass cleaner, ammonia, or soap and water. Never use any solvent-type cleaner such as alcohol or acetone. **Do not use gun cleaner to clean or lubricate the HWS®.**
3. All moving parts of the sight are permanently lubricated with the exception of the quick release lever. If audible sounds are generated when opening/closing lever, add a drop of lubricant to lever assembly. Do not try to lubricate any other moving part.
4. Never disassemble the sight's optical assembly! The optical cavity is purged, nitrogen filled, and sealed to achieve fog resistant performance. **Disassembly will void the warranty and damage the sight.**

## 2.3 Troubleshooting

The following section outlines measures the operator can take in the event of the named failure.

**Failure:** The sight will not power up:

Corrective Action 1: Ensure that the sight is off, and not ON at a very low brightness setting, by pressing both the UP and Down buttons simultaneously.

Corrective Action 2: Ensure the battery is inserted properly. The positive (+) end

should be positioned on the side of the battery cap.

Corrective Action 3: Replace the battery with a new, unused battery that contain a full charge.

Corrective Action 4: Inspect the battery contact points in both the battery cap and in the sight itself. Ensure that they are free of debris or corrosion.

Corrective Action 5: Reset the electronics by removing any source of power for approximately two minutes. This will allow a capacitor in the electronics housing to drain of power, resetting the electronics. Reinstall the battery and operate the sight as normal.

Corrective Action 6: Check the battery contacts for corrosion or wear. Clean the contacts.

Corrective Action 7: Turn in the sight for unit level maintenance.

**Failure:** The reticle is fuzzy/ has a 'halo' effect/ has more than one reticle:

The reticle is naturally pixilated and the outer circle will appear to be made up of many small dots. The center circle will still be distinguishable as one dot.

Corrective Action 1: Lower the brightness level of the reticle. This fault is generally caused by the reticle brightness being too high. The reticle is not designed to be so bright as to block the target.

Corrective Action 2: The reticle is projected onto your target plane. You must focus on it like you would any other object at that distance. Do NOT focus on the sight housing, rather, focus on your target. The outer ring is designed to be a reference to center, similar to a ghost ring.

Corrective Action 3: If you wear corrective lenses for nearsightedness, you will require them, not reading glasses, to see the reticle in focus, as it is projected onto the target plane. If you wear bifocals or have astigmatism, you may see a distorted reticle.

Corrective Action 4: Check with others who have used the sight, and compare what you see to ensure it is not your focal acuity prior to turning the sight in for repair.

Corrective Action 5: Turn the sight in for unit level maintenance.

**Failure:** The reticle is flashing/ flashing on and off/ unit turns off during recoil:

Corrective Action 1: This is the low battery indicator. Replace the battery.

Corrective Action 2: If the battery is low, a high recoil weapon platform can cause the reticle to flash on and off, even before the low battery indicator takes effect. Replace the battery.

Corrective Action 3: Replace the battery with an Energizer brand battery. These have proven to be the most effective to withstanding a consistent amount of recoil. Many brands of batteries deteriorate faster than others and can result in these failures.

Corrective Action 4: Turn the sight in for unit level maintenance.

**Failure:** There is a streak in the reticle/ the reticle is dim/ the reticle fades in parts of the window:

Corrective Action 1: Replace the battery.

Corrective Action 2: Check with others who have used the sight, and compare what you see to ensure it is not your focal acuity prior to turning the sight in for repair.

Corrective Action 3: Turn in for unit level maintenance.

## 2.4 Unit Level Maintenance and Repair

The Unit Armorer or individual responsible for unit level maintenance is only authorized to replace or repair the following items:

- Battery
- Battery Cap
- Quick release, adjustable base
- Protective Hood and Hood Screws
- Quick Reference Card

Please see Additional Authorized Items in Appendix A for the corresponding NSN numbers for the above listed components.

If the sight has been turned in for unit level maintenance that requires action in addition to the above mentioned authorized repair or replacement items, the sight will need to be returned to the manufacturer for the repair.

Contacting the manufacturer for repair:

1. Visit the manufacturer's website at <http://www.eotechinc.com>. Click on the Service and Support Tab in the menu bar and follow the instructions.

2. Call or email L-3® EOTech®'s Customer Service Department at the following:  
(734) 741-8868 x2176  
[general.eotech@L-3com.com](mailto:general.eotech@L-3com.com)
  
3. Be sure to leave a name, contact number, return shipping address, and failure description in the email or on a voice mail. This will allow the manufacturer to generate a Return Authorization Number (RA#) to include with the sight(s). **DO NOT SHIP THE SIGHTS WITHOUT A RETURN AUTHORIZATION NUMBER** (this will severely delay the turn around time on repair or replacement).
  
4. If you require, fill out a DD Form 1149 to include with the sight(s) you will return. Include a reference to the RA#, and a signature line for L-3® EOTech®'s Service Department to sign indicating the receipt of materials. The signed copy will be mailed, faxed, or emailed back to you upon receipt of the sight(s) for the purposes of accountability.
  
5. If the manufacturing date located on the bottom of the sight is more than Five years old, a fee will be assessed for repair to include the cost of both parts and labor. A purchase order will be required to process the repair. Please contact L-3® EOTech® for an estimate.

Please send the unit postage prepaid, to address listed in Appendix B. Please include your name, address, telephone number, and a written description of the problem you are encountering, and also include the RA #. Whenever possible, ship the sight in its original box.

## 2.5 Installation of Equipment

### MOUNTING

The EXPS is equipped with mounting hardware (see Figure 6) to attach to a 1" (25.4mm) Weaver or MIL-STD-1913 Picatinny style rail. To achieve the best results and accuracy, the HWS® must be mounted properly. The rail needs to be as parallel as possible to the bore to permit the maximum elevation and windage adjustments. If it is required, it is strongly recommended that the rail be installed by a qualified gunsmith. To mount the sight, please follow these steps.

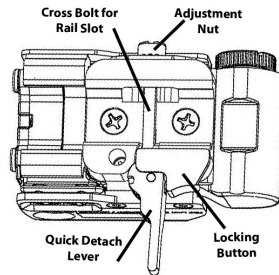

Figure 6

1. First, push the locking button inward, then turn the quick detach lever so it is away from its closed and nested position in the base of the sight. The locking button must be pushed down before pulling on the lever. This will expand the clamping interface to allow the sight to mount onto the rail.
2. The sight contains a small cross bolt that rests in the groove of the Picatinny rail. Move the sight to the position desired on the rail and allow the post to rest fully in the closest groove.
3. Push the sight as far forward as possible and close the quick detach lever so it is fully shut and nested in the base of the sight.
4. If at first the sight does not appear to be secure or the lever does not fully close, **open the quick detach lever**. Next, turn the adjustment nut opposite the quick detach lever clockwise for a tighter fit, and counterclockwise to accommodate wider rail tolerances until a proper fit is achieved. **CAUTION: Never make adjustments while the quick detach lever is in the closed position.**



## **2.6 Zeroing Procedures**

Once the weapon's iron sights have been zeroed, please refer to the section on Windage and Elevation Adjustments (Section 2.1.6) to zero the HWS®. The following are some additional reference aids that can be used during the zeroing process.

### **BORE SIGHTING**

Bore sighting is a good preliminary procedure in achieving proper alignment of your sight to the firearm. A chamber laser/ bore sighter is an aid in achieving collimation.

## USING THE 2-DOT BALLISTIC RETICLE

The EXPS2 offers a unique 2-dot ballistic reticle option assisting in short to long range applications. The 2 dots can be distinguished with or without magnification. This simple design is calibrated to the specific trajectory of the M4 carbine but can work on many other weapon platforms. See figure 9.

LOAD	CENTER DOT FIRST ZERO	CENTER DOT SECOND ZERO	SECOND DOT ZERO	BOTTOM OF CIRCLE
<b>.223 Cal. 62 Gr., 2900 Vel.</b>	50 yds	200 yds	500 yds	7 yds
<b>.44 Mag. 240 Gr., 1300 Vel.</b>	25 yds	50 yds	165 yds	–
<b>12 Ga. Sabot 385 Gr, 1850 Vel.</b>	25 yds	100 yds	250 yds	–
<b>.50 Cal. Black Powder 350 Gr., 1850 Vel.</b>	25 yds	100 yds	250 yds	–

Figure 9 Ballistic Chart

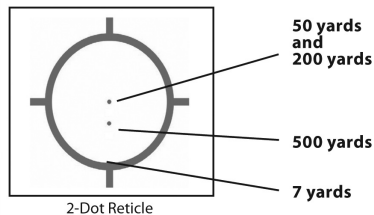

Figure 10 (2-dot reticle for a .223)

### **3.0 APPENDIX A: Components of End Item**

#### **3.1 REPLACEMENT ITEMS**

To obtain replacement parts that are able to be field installed for your HWS or Magnifier  
Please visit our Web page support link at:

<http://www.eotechinc.com/hws-service-and-support/parts-and-repair>

## 4.0 APPENDIX B: Factory Contacts

Customer Service/Repair ..... 888-EOTHOLO  
(734) 741-8868

Technical Sales/Service .....(734) 741-8868 x2176

Link to website to submit RA Request: ..... <http://www.EOTech-inc.com/raform.php>

Shipping Address:

L-3® EOTech® Inc.  
1201 E. Ellsworth Rd.  
Ann Arbor, MI 48108  
USA

EMAIL.....[general.eotech@L-3com.com](mailto:general.eotech@L-3com.com)

Visit us on the web ..... [www.eotechinc.com](http://www.eotechinc.com)

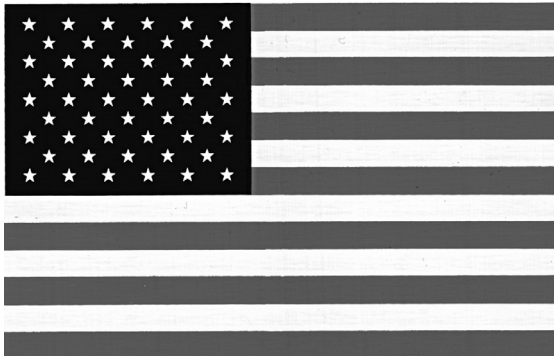

**OUR PRODUCT IS PROUDLY MANUFACTURED  
IN THE UNITED STATES OF AMERICA**

