

The Brownells/Marvel 1911 Auto Sear/Hammer Jig is designed to aid the gunsmith in doing "match quality" trigger jobs on 1911 Auto pistols. The combination jig and vise holds the sear and hammer in the proper relationship to give the best, most consistent trigger work.



WARNING



Never attempt to disassemble or reassemble a firearm unless you are absolutely certain that it is empty and unloaded. Visually inspect the chamber, the magazine and firing mechanism to be absolutely certain that no ammunition remains in the firearm. Disassembly and reassembly should follow the manufacturer's instructions. If such instructions are not immediately available, contact the manufacturer to see if they are available. If they are not available at all, then you should consult other reference sources such as reference books or persons with sufficient knowledge. If such alternative sources are not available and you have a need to disassemble or reassemble the firearm, you should proceed basing your procedures on common sense and experience with similarly constructed firearms.

With regard to the use of these tools, the advice of Brownells Incorporated is general. If there is any question as to a specific application it would be best to seek out specific advice from other sources and not solely rely on the general advice and warnings given.

HOW TO USE

Before starting any work, be sure to have all of the necessary components, tools and accessories on hand.

Sequence of operations:

- 1) Fit a new trigger to the frame if an adjustable, overtravel-type trigger is to be used.
- 2) Make sure the sear and hammer will fit into the frame if new parts are being used.
- 3) Make certain the sear and hammer pins are not overly loose in the frame and the sear and hammer are not excessively loose on their pins. Replace the pins with new or oversize pins if necessary, fitting them per the manufacturer's instructions.
- 4) Prepare the hammer: (Note: It is absolutely vital that the hammer be properly prepared. If the hooks are not cut at exactly 90° and perfectly polished with the hook height set at .018" to .020", then it will be impossible to obtain a consistent, reliable, clean, crisp trigger pull, no matter how much work is done to the other components of the pistol. The best components will be wasted if this work is not done properly!)
 - A) True the hammer hooks to 90° to the hammer flats if necessary, using a Brownells Hammer Hook Squaring File. Do not cut the hooks forward any more than is necessary to square them.
 - B) Reduce the hammer hook height to .018" to .020", keeping the top of the hooks square to the hook face. (Figure 1)
 - C) Place the right lower end of the Jig in a bench vise. Note: A smooth jawed bench vise is recommended, or if not available, smooth metallic jaws will protect the Jig. (See illustration 1)
 - D) Using the 4mm/16mm screw, install the hammer in the hammer vise portion of the Jig.
 - E) Place the hammer vise in Slot B and lightly tighten, using the Allen head screw taken from Sear Jig's insert.
 - F) Turn the stoning guide upside down and place on the top edge of the Jig. (See illustration 2)
 - G) Use the height adjusting screw to move the hammer vise up until the hammer flats are level and mate evenly with the lower side of the inverted stoning guide.
 - H) Tighten the Allen head screw to hold the hammer vise in place.
 - I) Double check the hammer flats to ensure they are perfectly level, then tighten the vise screw (3mm Allen wrench) to hold the hammer in the correct position.
 - J) Turn the stoning guide over and position the legs of the stoning guide in the slots in the jig body. Lightly stone the hammer hooks. We rec-

BROWNELLS/MARVEL

1911 AUTO SEAR/HAMMER JIG

#080-823-000



READ & FOLLOW THESE
INSTRUCTIONS

BROWNELLS

SELECTION. SERVICE. SATISFACTION.®

200 S. Front St. Montezuma, IA 50171
800-741-0015 or 641-623-4000 • www.brownells.com

World's Largest Supplier of
Firearms Accessories and Gunsmithing Tools.™

ommend Brownells Hammer/Sear Stone Kit (#080-811-000) with its 6" x ½" x ½" stones for this operation. Use plenty of cutting oil with the india stone, or water as a cutting agent for the ceramic stones in this kit. You may wish to protect the sides of the stoning guide from abrasion by use of a thin piece of steel shim stock between the stone and the guide. Remove very little metal; just enough to correct the angle or to polish the hook surfaces.

K) Inspect the hammer hooks for the correct angle. Refer to the illustrations of hammer hook angles. (See illustration 3)

5) Prepare the Sear:

PRIMARY ANGLE

- A) Firmly tighten the sear insert into Slot A on the Jig body. (Figure 2)
- B) Place the sear on the sear post as shown in Figure 3 and lightly thread the nut on the post. Do not overtighten.
- C) Insert the spare hammer pin through the hammer and install the hammer on the jig so the hammer hooks will line up with the sear face. (Figure 3)
- D) When the hammer and sear are correctly aligned as they would be with the pistol cocked, tighten the nut firmly on top of the sear. Note: overtightening the nut could cause the post to pull away from the sear insert.
- E) With the sear locked in place with the nut, remove the hammer and hammer pin from the Jig. Remove the sear insert from Slot A and place it in the Jig's slot B.
- F) Lightly tighten the insert in Slot B using the Allen head screw on the back of the insert.
- G) Use a layout fluid such as Dykem Steel Blue to lightly coat the sear's engaging surface.
- H) Use the adjusting screw to position the insert so the sear engaging surface is slightly above the level of the top of the Jig. Remember that you will be removing very little metal from the sear...only about .002" to .006".
- I) Lock the insert in position and double check the height.

J) Stone across the top of the sear until the stone is level with the top of the Jig. (Figures 4 and 5)

K) Remove the sear insert from slot B and repeat steps A through J, above. Use a finer grit stone than was used previously.

SECONDARY ANGLE

A) Remove the insert from slot B and place in slot C.

B) Adjust the sear so the sear's point is slightly above the level of the top of the Jig.

C) Tighten in place using the Allen head screw on the back of the insert.

D) Stone across the top of the sear point until the stone is level with the top of the Jig. (Figure 6)

E) The finished sear should have approximately .020" engaging surface remaining on the primary angle after the secondary angle has been cut. (Figure 7)

F) Apply layout fluid (Dykem) to the sear. Check the sear's engagement with the hammer. We recommend using Brownells Trigger Adjustment Pins on the outside of the frame to check engagement. (Figures 8 & 9)

6) If the engagement checks out okay, test-assemble the sear and hammer in the frame and double check the engagement with all the related parts assembled, including any replacement springs.

7) Perform any other work related to the action job.

A) This is the proper point in the work sequence to fit new thumb or grip safeties.

B) Deburr and polish the mainspring housing hole for the mainspring. Make sure the mainspring cap is polished and free to move within the mainspring housing. If desired, replace the mainspring housing with a lighter weight mainspring. (17 to 18lbs.)

C) Lightly polish the surfaces that contact the sear and disconnect. Adjust the tension (bend) of the sear spring fingers.

D) Colt Series 80 guns: Polish the flat surfaces and mating surfaces of the trigger bar lever, plunger and the firing pin plunger. Deburr the surfaces of the frame and slide were the Series 80 parts touch them.

8) Reassemble the pistol and **check all safeties for proper functioning.**

NOTE: After doing action work on an autoloading pistol, the existing safeties may need to be refitted. Be certain the thumb safety properly blocks the sear and the grip safety blocks the trigger when in the "en-

gaged" position. In addition, the disconnecter may need to be replaced or refitted, especially if the slide has been tightened. If your pistol is a Colt Series 80, be sure the firing pin lock safety features work properly to lock the firing pin rearward until the trigger is pulled. You may have to refit the existing parts or replace components of the firing pin lock system to ensure when the trigger is pulled, the firing pin block plunger is cammed out of engagement with the firing pin.

TROUBLE SHOOTING

A) Hammer Follows The Slide Forward:

- 1) Use layout fluid (Dykem) on the hammer hooks with the sear and hammer in the frame to check if the sear is mating with only one hook. If it is, correct by lightly stoning and then polishing the engaging surface. Repeat until the sear bears evenly on both hammer hooks.
- 2) Check the hammer hooks for the correct height and angle.
- 3) Check the sear spring for correct shape and tension.
- 4) Replace the steel trigger with a lighter aluminum or composite trigger.
- 5) Review the instructions given for preparing the hammer and sear and double check that you have followed them.

B) Heavy Trigger Pull or Creep:

- 1) With the gun unloaded, burnish the hammer hooks by applying pressure to the back of the hammer in the full cock position while pulling the trigger until it release.
- 2) It is possible the sear is too short from excessive stoning and/or tolerance stacking of the frame's set up with minimal metal removal.
- 4) See A), 1), 2) and 3) above.

C) Trigger Pull Too Light:

- 1) Decrease the sear's secondary angle.
- 2) See A), 1), 2) and 3) above.

For additional information in action work on Colt 1911-type pistols, we recommend Jerry Kuhnhausen's book *The Colt .45 Automatic, A Shop Manual*. Valuable information can also be found in *.45 Auto Custom Touches*, by R. D. Nye. These books, as well as others by recognized authorities, can be obtained from Brownells, Inc.

If you have any problems or need additional information, do not hesitate to contact our technical staff.

FIGURE 1:

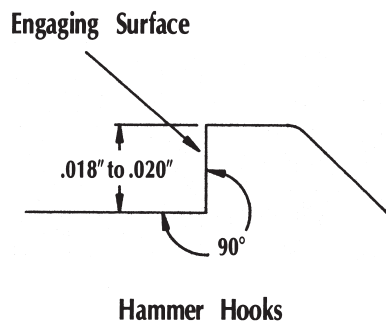

ILLUSTRATION 1:

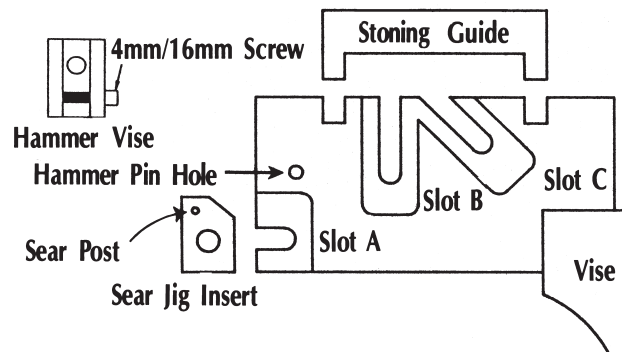

FIGURE 2:

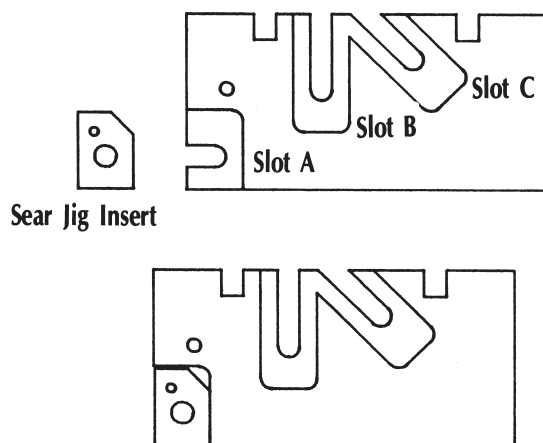

ILLUSTRATION 2:

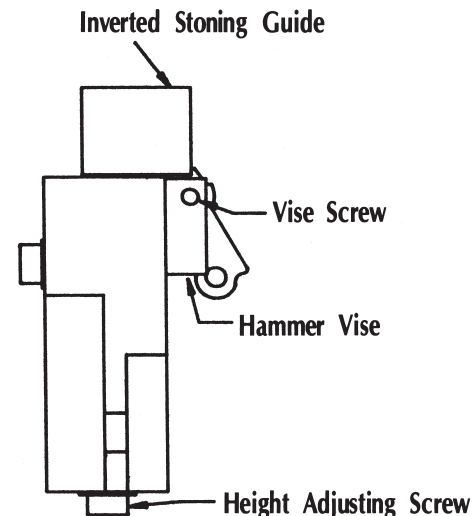
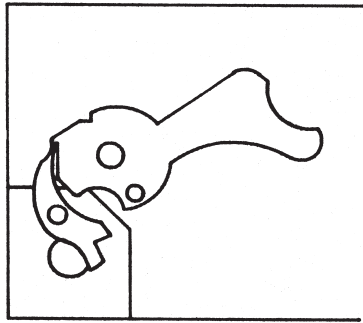

FIGURE 3:



Mating Hammer-Sear
Lock Sear Into Place

ILLUSTRATION 3:

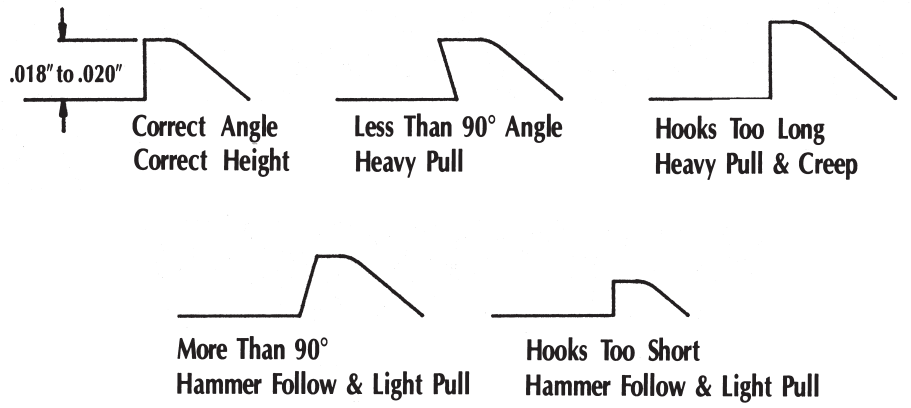
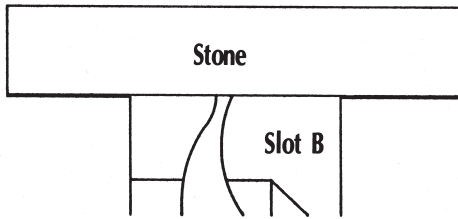

FIGURE 4:



Stoning Engaging Surface

FIGURE 5:

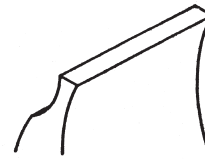
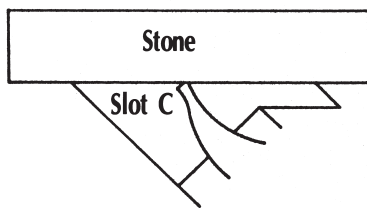
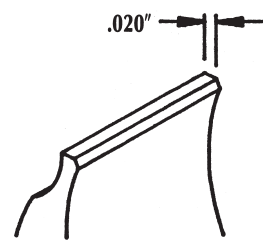

FIGURE 6:



Stoning Secondary Angle

FIGURE 7:



Finished Sear

FIGURE 8:

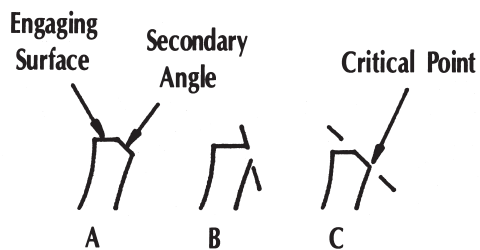

Properly Cut Sear

FIGURE 9:

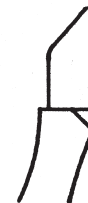

Properly Mated Sear-Hammer

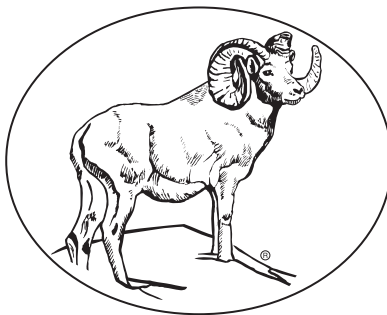

BROWNELLS
SELECTION. SERVICE. SATISFACTION.[®]

200 S. Front St. Montezuma, IA 50171
800-741-0015 or 641-623-4000
www.brownells.com

World's Largest Supplier of Firearms Accessories and Gunsmithing Tools.™